

RG-100

(01.011)

| | | | | | |
|-----------------|------|------|--------------------|---------------------|-----------------|
| Motor | (kW) | 0,55 | max. airflow | (m ³ /h) | 1.000 |
| Voltage | (V) | 400 | Max. neg. pressure | (Pa) | 1.400 |
| Current | (A) | 1,5 | Outtake | (mm) | 100 |
| Rated frequency | (Hz) | 50 | Intake | (mm) | 100 |
| Fuse | (A) | 16 | Weight | (kg) | 22 |
| | | | Dimensions | (mm) | 535 x 450 x 480 |

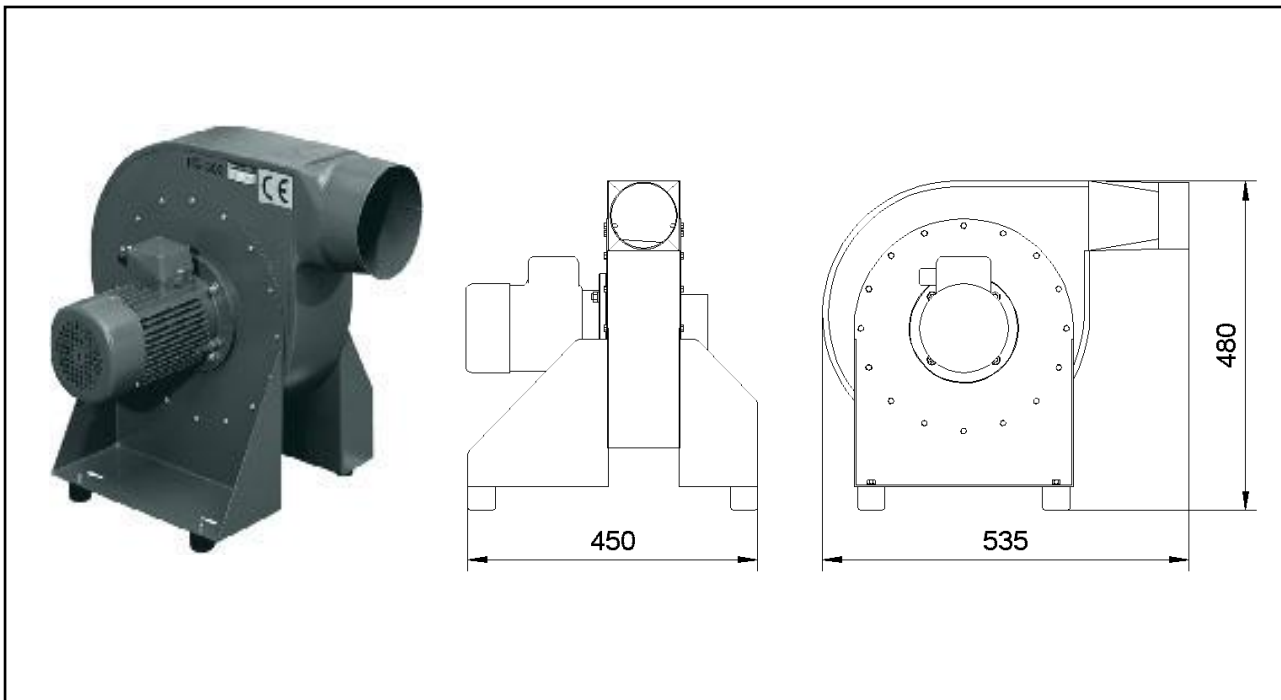

ESTA PLUS

Application range:

- Extraction of individual and multiple
- workstations in industrial and skilled trade applications

Characteristics:

- Adjustable exhaust air outlet

Your benefits at a glance:

- High performance
- Heavy duty construction
- Low operating costs
- Wide range of applications

Modification:

- AC current
- Stainless steel (V2 A)
- Motor mounted on the left hand side
- ignition free
- special painting

State of the art: 01011-51-00 Subject to change without notice! For remaining questions, please do not hesitate to contact us.

ESTA Apparatebau GmbH & Co. KG
Gotenstraße 2 – 6
89250 Senden

Telefon 07307 804-0
Telefax 07307 804-500
E-Mail info@esta.com

www.esta.com