

## RG-700

(01.071)

Motor	(kW)	5,5	max. airflow	(m <sup>3</sup> /h)	7.000
Voltage	(V)	400	Max. neg. pressure	(Pa)	3.500
Current	(A)	11	Outtake	(mm)	315
Rated frequency	(Hz)	50	Intake	(mm)	315
Fuse	(A)	25	Weight	(kg)	168
			Dimensions	(mm)	1.116 x 950 x 1.036

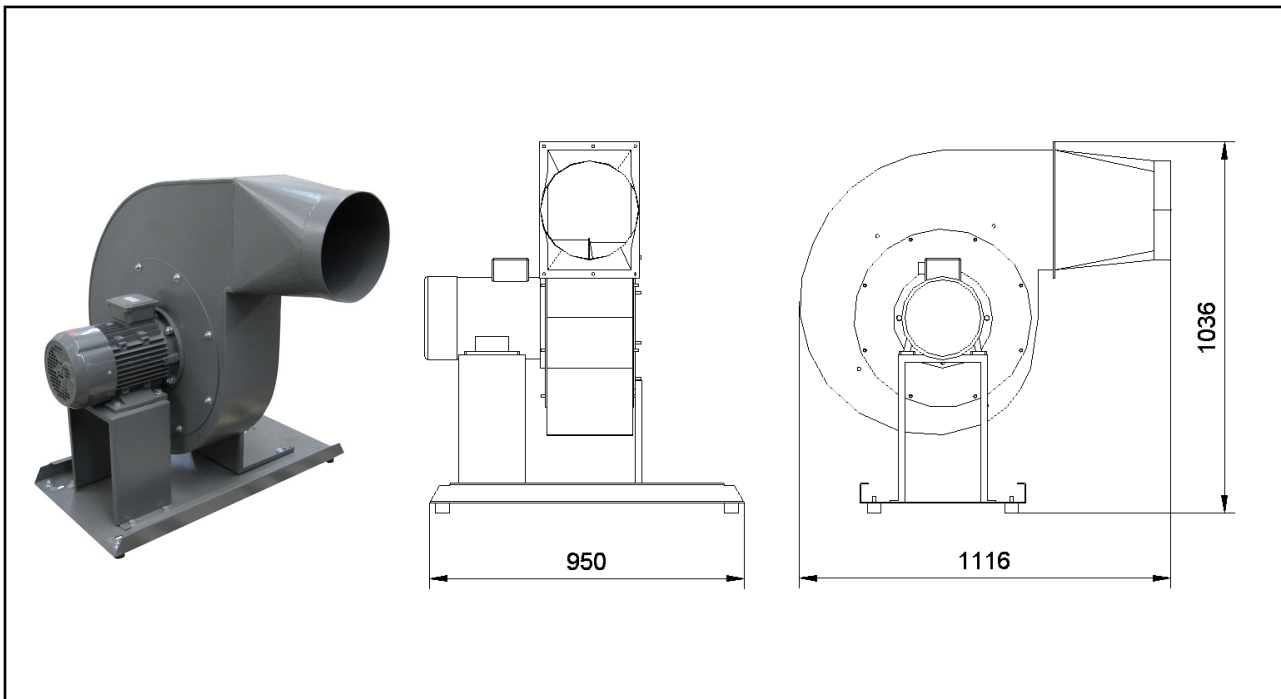

## ESTA PLUS

### Application range:

- Extraction of individual and multiple
- Workstations in industrial and skilled trade applications

### Characteristics:

- Adjustable exhaust air outlet

### Your benefits at a glance:

- High performance
- Heavy duty construction
- Low operating costs
- Wide range of applications

### Modification:

- AC current
- Stainless steel (V2 A)
- Motor mounted on the left hand side
- Ignition free
- Special painting

State of the art: 01071-51-00 Subject to change without notice! For remaining questions, please do not hesitate to contact us.

ESTA Apparatebau GmbH & Co. KG  
Gotenstraße 2 – 6  
89250 Senden / GERMANY

Phone +49 7307 804-0  
Fax +49 7307 804-500  
E-Mail info@esta.com

[www.esta.com](http://www.esta.com)