

## RG-100 with dust filter bag

(04.011)

Voltage	(V)	400	Max. neg. pressure	(Pa)	1.400
Motor	(kW)	0,55	Max. airflow	(m <sup>3</sup> /h)	1.000
Current	(A)	4,5	Weight	(kg)	22
Rated frequency	(Hz)	50	Intake	(mm)	100
Fuse	(A)	16	Dimensions (l x w x h)	(mm)	1.000 x 535 x 1.550

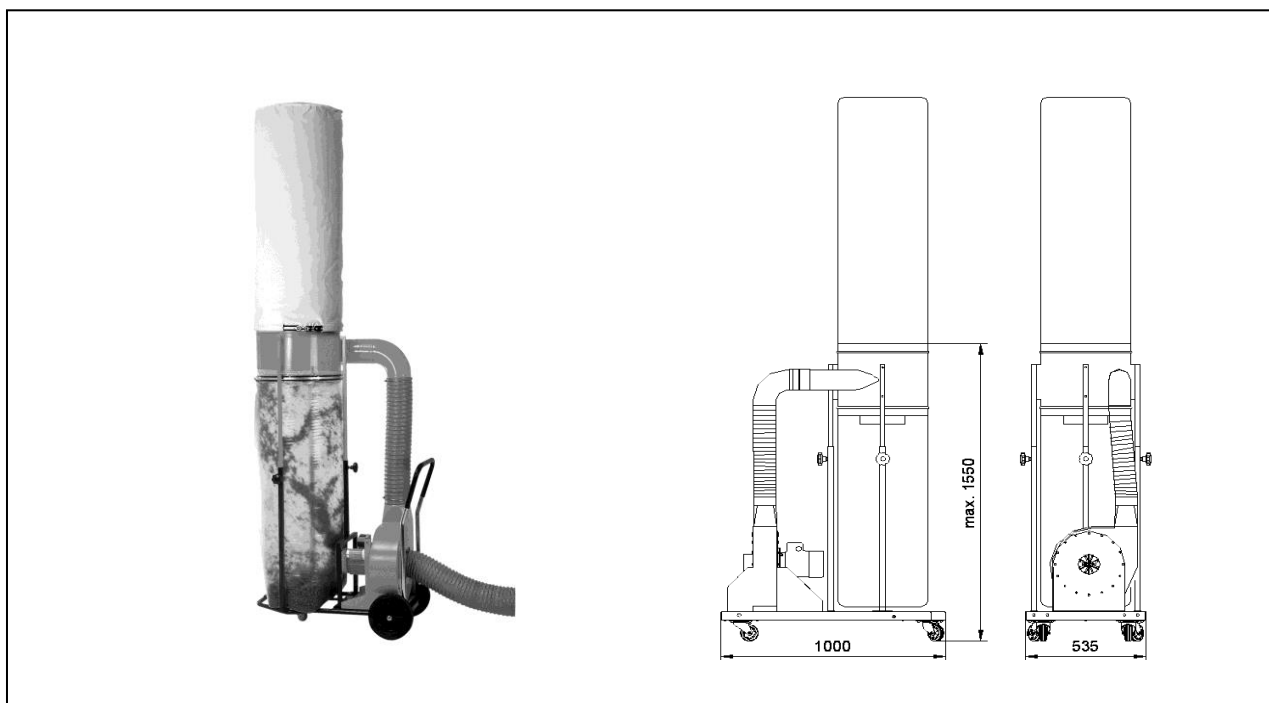

## ESTA PLUS

### Application Range:

Extraction of low quantity of dust  
in industrial and skilled trade applications

### Your benefits at a glance:

High performance  
Heavy duty construction  
Low operating costs  
Wide range of applications

### Characteristic:

mobile, flexible extraction unit

### Optional features:

AC current, Stainless steel (V2 A), special voltage,  
ignition free, special painting

State of the art: 04011-51-00 Subject to change without notice! For remaining questions please do not hesitate to contact us.