

VACUMAT 1000

(07100)

Motor	(V)	1.1	max. neg. pressure	(Pa)	1,250
Voltage	(kW)	400	Sound level	(dBA)	62
Rated frequency	(Hz)	50	Mass activated carbon	(Kg)	25
Ampere	(A)	2.4	No. of filter elements	(pc)	1
Fuse	(A)	16	Dimensions (L x W x H)	(mm)	1,050 x 800 x 1,330
max. air flow	(m ³ /h)	1,010	Weight	kg	215

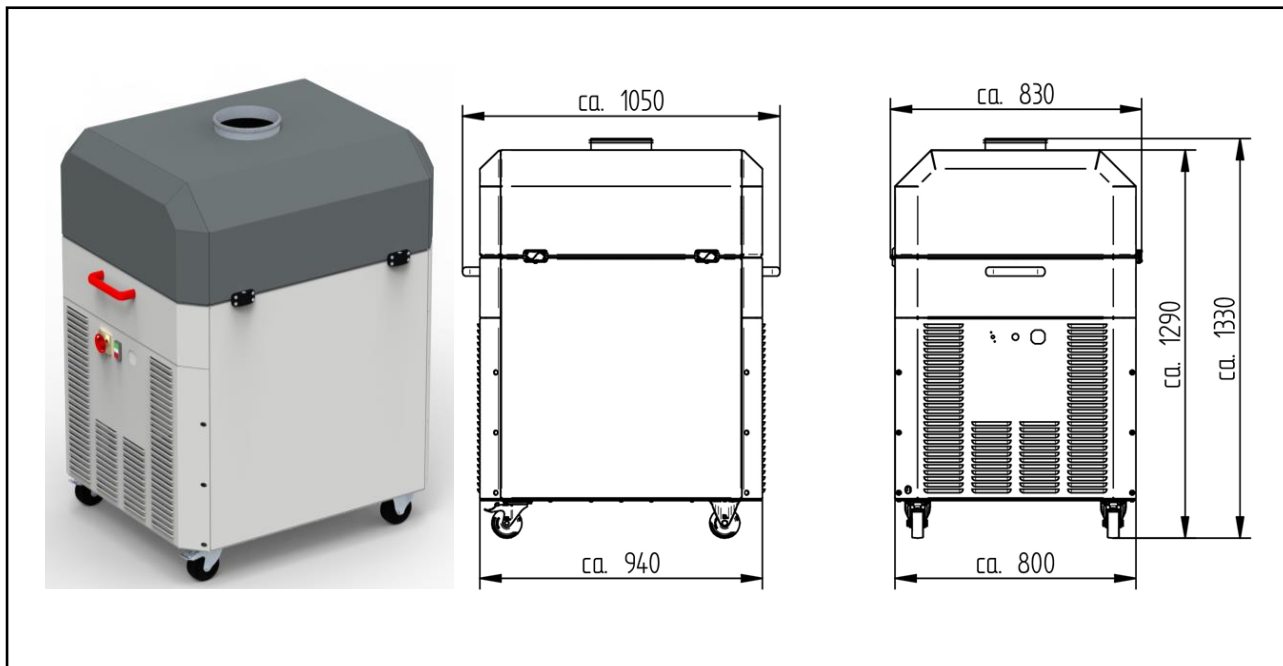

ESTA PLUS

Application range:

- Mobile filter unit with activated carbon for the adsorption of gaseous pollutants and disturbing odors

Characteristics:

- Pre filter
- Prepared for installation of ESTA extraction arm
- Activated carbon filter cell with granular activated carbon
- Mounted with rolls

Your benefits at a glance

- Compact and powerful
- Extremely quiet operation
- Low operating costs
- New innovative cabinet design, therefore providing a small footprint
- Operating hours counter for monitoring the filter lifetime

State of the art: 07100-51-01 Subject to change without notice! For remaining questions, please do not hesitate to contact us.