

# DUSTOMAT 10 (230V)

(09.201)

Voltage	(V)	230	Filter surface	(m <sup>2</sup> )	3,5
Motor	(kW)	1,3	No. of filter elements	(pc)	2
Ampere	(A)	8,0	Filter cleaning	manual brush cleaning	
Rated frequency	(Hz)	50	Filter material	„M“-classified	
Fuse	(A)	16	Intake	(mm)	100
max. neg. pressure	(Pa)	2,800	Weight	(kg)	120
max. air flow	(m <sup>3</sup> /h)	720	Dust collection bin	(liter)	100
Sound level	dB(A)	73	Dimension (L x W x H)	(mm)	1.165 x 530 x 1.636

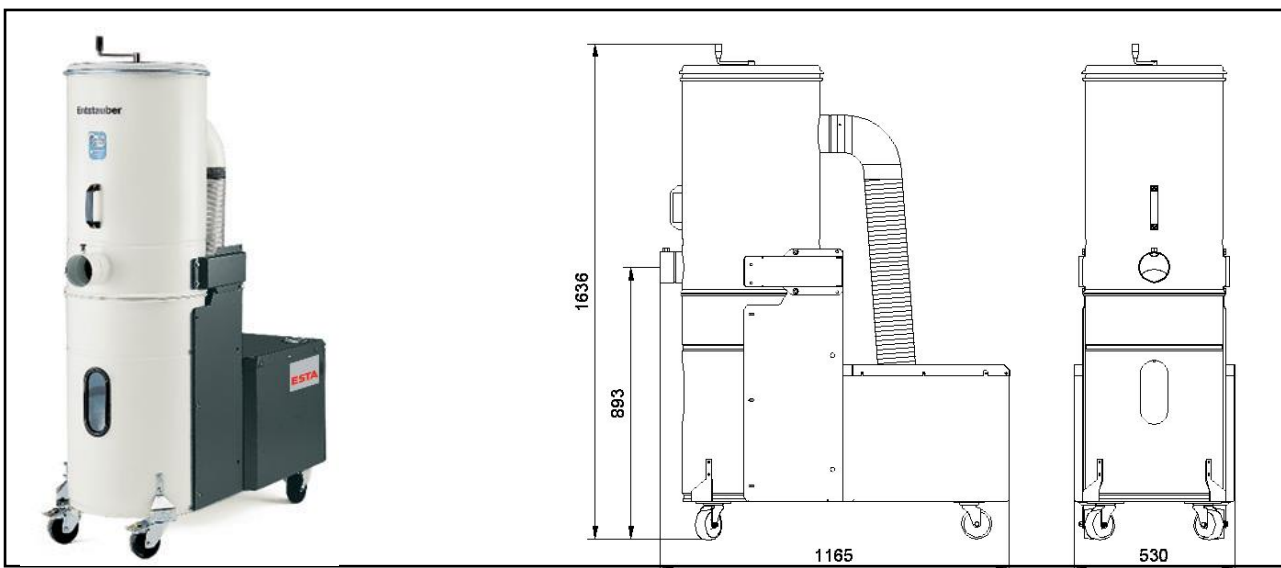

## ESTA PLUS

### Application range:

- Dust extraction of individual machines and manual workstations
- Pourable dust types – including hazardous types of dust

### Your benefits at a glance

- Low operating costs resulting from cleanable long life filter cartridges
- Mobility combined with high extraction performance
- Tilt-back filter housings for easy dust disposal
- Suitable for most types of dustExtremely quiet operation

### Characteristics:

- Filter cleaning method:  
Brush cleaning method (manually)Cleanable long life cartridge filters (dust classification M)
- Mobile on rolls

### Custom design/optional:

- Special equipment with different filter cartridges
- exhaust air socket with floating contact
- special voltage
- special painting
- pre-separator
- floor and machine cleaning tools possible

State of the art: 09201-51-02 Subject to change without notice! For remaining questions, please do not hesitate to contact us.

ESTA Apparatebau GmbH & Co. KG  
Gotenstraße 2 – 6  
89250 Senden / GERMANY

Phone +49 7307 804-0  
Fax +49 7307 804-500  
E-Mail info@esta.com

[www.esta.com](http://www.esta.com)