

DUSTOMAT 16 M

(09.422)

Voltage	(V)	400	Filter surface	(m ²)	9,4
Motor	(kW)	1,1	No. of filter elements	(pc)	1
Ampere	(A)	2,39	Filter cleaning		Jet-Pulse
Rated frequency	(Hz)	50	Filter material		„M“-classified
Fuse	(A)	16	Intake	∅ (mm)	125
max. neg. pressure	(Pa)	2,000	Weight	(kg)	110
max. air flow	(m ³ /h)	1,140	Dust collection bin	(liter)	45
Sound level	dB(A)	73	Dimension (L x W x H)	(mm)	1.150 x 670 x 1.470
Comp. air connection	(inch)	¼			

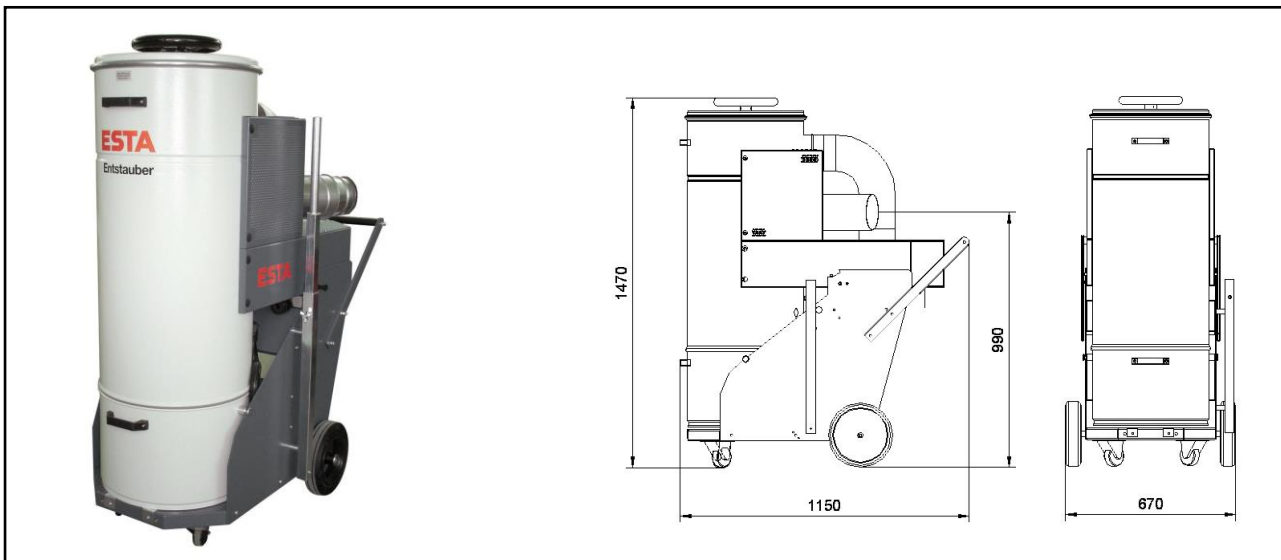

ESTA PLUS

Application range:

- Dust extraction of individual machines and
- Manual workstations
- Pourable dust types
- Suitable for extraction of hazardous types of dust (particular mineral dusts)

Your benefits at a glance

- Low operating costs
- cleanable long life filter cartridges
- Mobility combined with high extraction performance
- Tilt-back filter housings for easy dust disposal
- Suitable for most types of dust
- Extremely quiet operation

Characteristics:

- Filter cleaning method: Jet-Pulse
- Cleanable long life cartridge filter (dust classification M)
- Test Certificate dust classification „M“
- Equipped with volume stream control and acoustic signal transmitter

Custom design/optional:

- Special equipment with different filter cartridges
- special voltage
- special painting

State of the art: 09422-51-02 Subject to change without notice! For remaining questions, please do not hesitate to contact us.

ESTA Apparatebau GmbH & Co. KG
 Gotenstraße 2 – 6
 89250 Senden / GERMANY

Phone +49 7307 804-0
 Fax +49 7307 804-500
 E-Mail info@esta.com

www.esta.com