

DUSTOMAT 100-S / 400 V

(09.497)

Voltage	(V)	400	Filter surface	(m ²)	0,75
Motor	(kW)	1,1	No. of filter elements	(pc)	1
Ampere	(A)	2,6	Filter material	cotton with paper filter bag	
Rated frequency	(Hz)	50	Intake	∅ (mm)	100
Fuse	(A)	16	Weight	(kg)	100
max. neg. pressure	(Pa)	2,800	Dust collection bin	(liter)	100
max. air flow	(m ³ /h)	720	Dimension (L x W x H)	(mm)	1.075 x 530 x 1.075

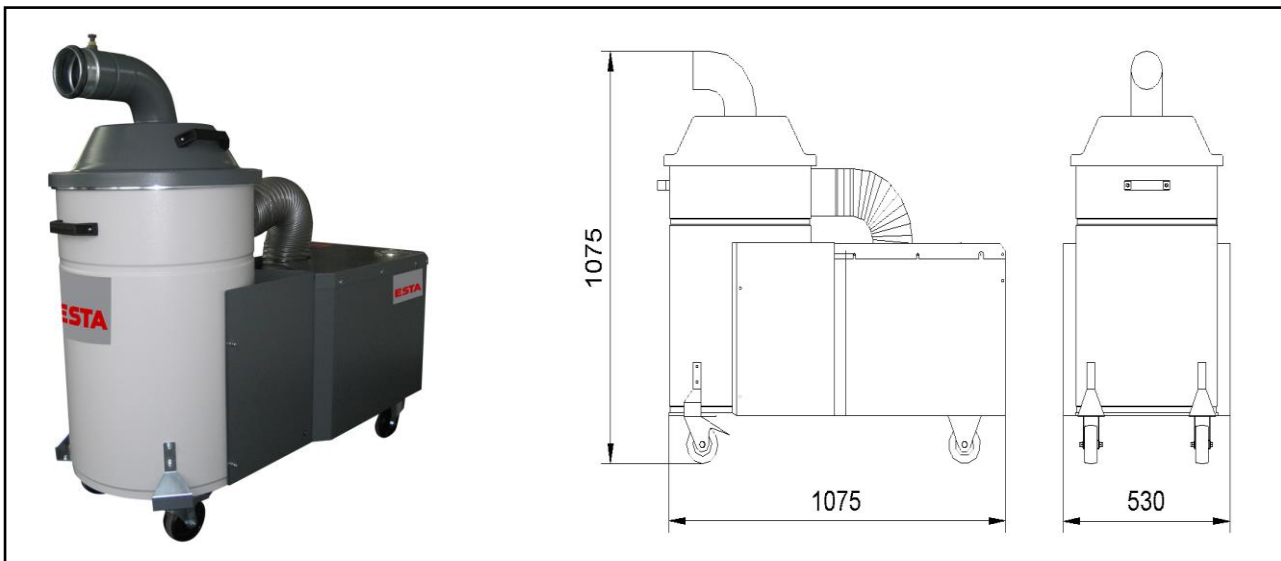

ESTA PLUS

Application range:

- Extraction in textile and flocking industry, Manual workstations
- Especially suitable for the extraction of sticky and fibrous dust and dust that tend to clump

Your benefits at a glance

- Specialized dust extractor for sticky dust and dust containing long fibres
- Compact design with high extraction performance
- Easily replaceable paper filter bag to collect the dust

Characteristics:

- Filter: Fabric filter element with primary paper filter bag

Custom design/optional:

- Optional type examination certificate special voltage

State of the art: 09497-51-01 Subject to change without notice! For remaining questions, please do not hesitate to contact us.

ESTA Apparatebau GmbH & Co. KG
Gotenstraße 2 – 6
89250 Senden / GERMANY

Phone +49 7307 804-0
Fax +49 7307 804-500
E-Mail info@esta.com

www.esta.com