

## DUSTOMAT 4-24

(09.760)

|                    |                     |       |                        |                     |                     |
|--------------------|---------------------|-------|------------------------|---------------------|---------------------|
| Voltage            | (V)                 | 400   | Filter surface         | (m <sup>2</sup> )   | 24                  |
| Motor              | (kW)                | 4.0   | No. of filter elements | (pc)                | 2                   |
| Rated frequency    | (Hz)                | 50    | Filter cleaning        | Jet cleaning system |                     |
| Fuse               | (A)                 | 16    | Weight                 | (kg)                | 280                 |
| Intake             | (mm)                | 200   | Dust collection bin    | (liter)             | 38                  |
| max. neg. pressure | (Pa)                | 3,600 | Dimension (L x W x H)  | (mm)                | 1,590 x 945 x 1,640 |
| max. air flow      | (m <sup>3</sup> /h) | 3,300 | Comp. air requirement  | (l/impuls)          | approx. 19          |
| Sound level        | dB(A)               | 73    | Comp. air connection   | (bar)               | 4 – 6               |

\*at 4 bar with valve opening 0,12 sec

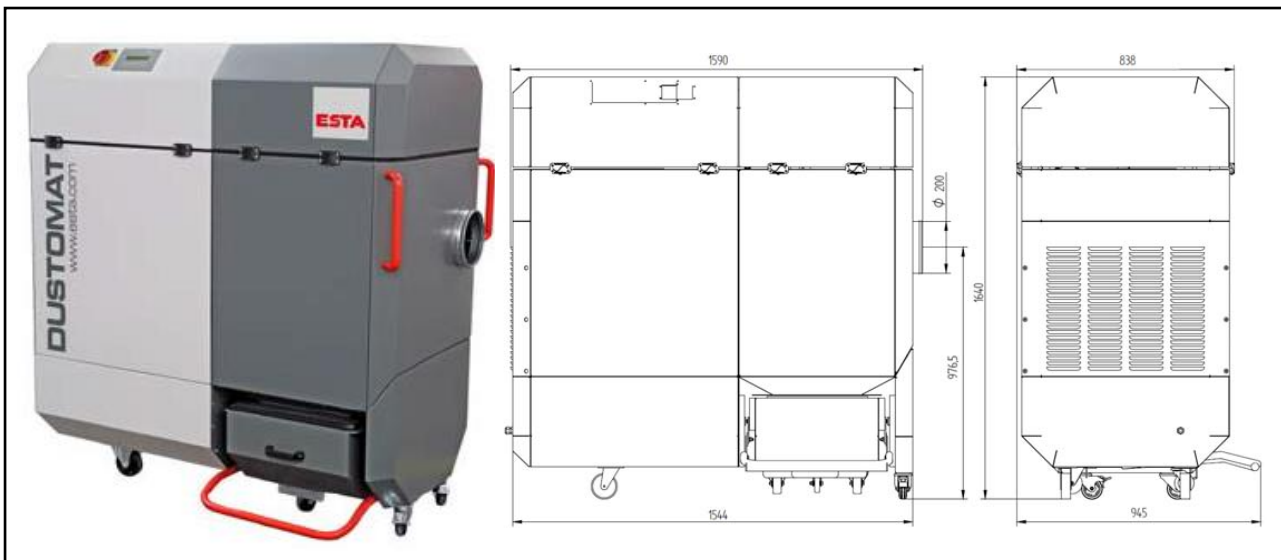

## ESTA PLUS

### Application range:

- Dust extraction at individual or multiple workstations or
- machines in industrial plants or smaller shops
- Pourable dust
- Dry chips

### Your benefits at a glance

- All-purpose for dust and shavings
- Compact and powerful
- Low operating costs
- Convenient dust disposal
- Extremely quiet operation
- Test certificate for special application
- New innovative cabinet design, therefore providing a small footprint

### Characteristics:

- Pulse-jet filter cleaning system
- Cleanable long life cartridge filters (dust classification M)
- Integrated impact separator
- Mobile dust collection drawer for easy disposal
- Total capacity dust collection bin ~90 l
- Mobile on rolls

### Custom design/optional:

- stationary
- ATEX-Modification
- with Backup filter cassette (dust class H)
- with floating contact

State of the art: 09760-51-01 Subject to change without notice! For remaining questions, please do not hesitate to contact us.

ESTA Apparatebau GmbH & Co. KG

Gotenstraße 2 – 6

89250 Senden / GERMANY

Phone +49 7307 804-0

Fax +49 7307 804-500

E-Mail info@esta.com

[www.esta.com](http://www.esta.com)