

MOBEX F-40

(09.837)

Motor	(kW)	3,0	Filter surface	(m ²)	40
Voltage	(V)	400	No. of filter elements	(pc)	2
Rated frequency	(Hz)	50	Filter cleaning		Jet-Pulse
Fuse	(A)	16	Dust collection drawer	(liter)	100 - 150
max.airflow	(m ³ /h)	2.800	Dimensions (L x W x H)	(mm)	1.910x1.040x2.030
max. neg. pressure	(Pa)	3.400	Weight	(kg)	ca. 310
Intake	(mm)	224	Comp. air requirement	(l/impuls)	ca. 19
Sound level	(dBA)	71	Comp. air connection	(bar)	4-6

* with 4 bar and valve opening time of 0,12sec

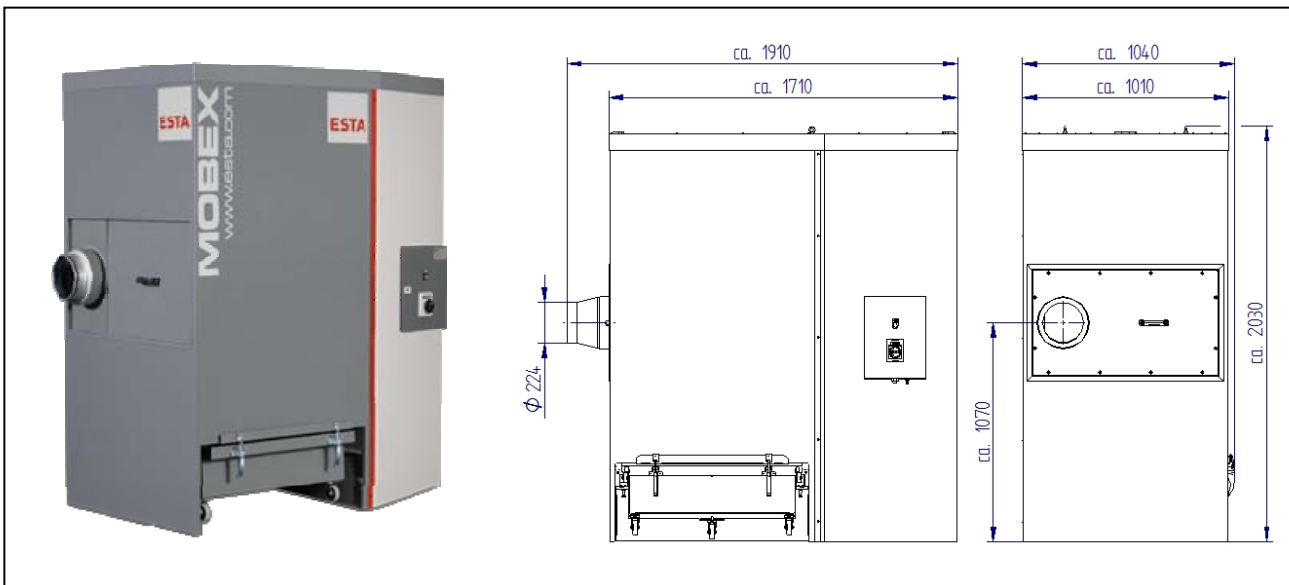

ESTA PLUS

Application range:

Single and multiple extraction in industrial plants or smaller workshops
Dry, pourable, non-flammable welding fumes

Your benefits at a glance:

All-purpose for welding fumes
Tight and powerful
Convenient dust disposal
Low operation noise
Low operating costs

Characteristics:

Automatic jet pulse filter cleaning system
Cleanable long life cartridge filters (dust classification M)
Integrated impact separator
Easy replaceable dust collection bins
New housing structure of sandwich panel

Modification:

Filter cartridges with advanced properties
With pre-separator
Mobile on wheels (H + 107 mm)
With dry contact for external control
Exhaust air socket
Test certificates for special applications (W3)

State of the art: 09837-51-04 Subject to change without notice! For remaining questions please do not hesitate to contact us.