

## ESTA 70

(11.071)

Voltage	(V)	400	Max. airflow	(m <sup>3</sup> /h)	700
Motor	(kw)	0,55	Speed	(1/min)	2.800
Intake diameter	(mm)	70	Weight	(kg)	25
Max. neg. pressure	(Pa)	1.000	Dimensions (L x W x H)	(mm)	320 x 320 x 660
Fuse	(A)	1,5			

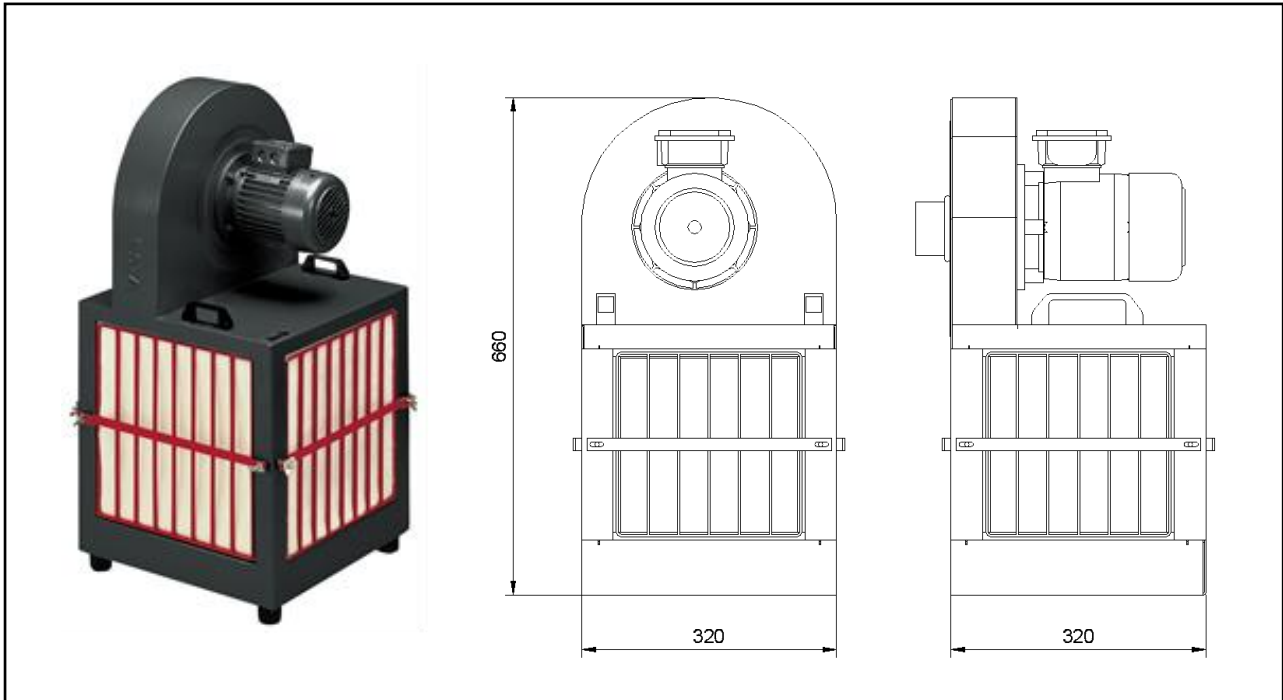

## ESTA PLUS

### Application range:

- Single extraction in industrial plants or smaller Workshops

### Your benefits at a glance:

- Low operating cost
- Wide range of applications
- Low maintenance
- Minimal space requirement
- Very easy to use

### Special Features:

- Stationary but compact enough to move around if necessary

### Optional

- With filter material PA 500
- With motor with alternating current
- With special painting

State of the art:: 11101-51-00 Subject to change without notice! For remaining questions please do not hesitate to contact us.