

## NA-K 1800 B

(45.182)

Voltage	(V)	400	Water capacity		290
Motor	(kW)	4,1	Water connection		G ¾"
Current (400V/50Hz)	(A)	8,5	Intake diameter	(mm)	180/280
Fuse	(A)	20	Weight (without water)	(Kg)	340
max. neg. pressure	(Pa)	4.300	Sludge tank	(Liter)	50
max. airflow	(m <sup>3</sup> /h)	2.160	Dimensions (L x B x H)	(mm)	800 x 800 x 2.920

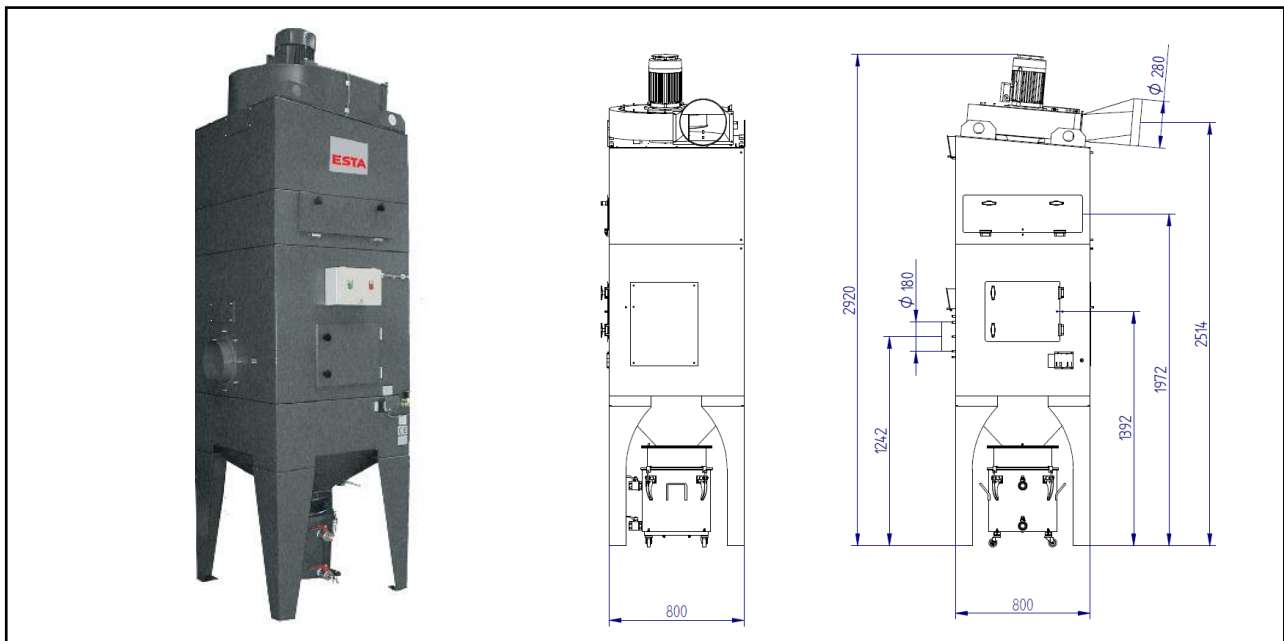

## ESTA PLUS

### Application range:

- Extraction of aluminium dust
- Dust extraction at individual or multiple workstations of adhesive and moistly dusts, especially metallic dusts that are sparks generating
- As central exhaust station with intercepting pipe and several extraction points

### Your benefits at a glance

- High suction power for adhesive and moistly dusts
- Ideal solution for sparks generating applications

### Characteristics:

- Partially made of stainless steel, epoxy resin based
- interior coating
- Integrated control cabinet

### Custom design/optional:

- with special painting

State of the art: 45182-51-04 Subject to change without notice! For remaining questions please do not hesitate to contact us..