

NA-K 1800

(45.183)

Voltage	(V)	400	Water capacity	290
Motor	(kW)	3	Water connection	G ¾"
Current (400V/50Hz)	(A)	10,4	Intake diameter	(mm) 180/280
Fuse	(A)	20	Weight (without water)	(Kg) 340
max. neg. pressure	(Pa)	4.300	Sludge tank	(Liter) 50
max. airflow	(m ³ /h)	2.160	Dimensions (L x B x H)	(mm) 800 x 800 x 2.920

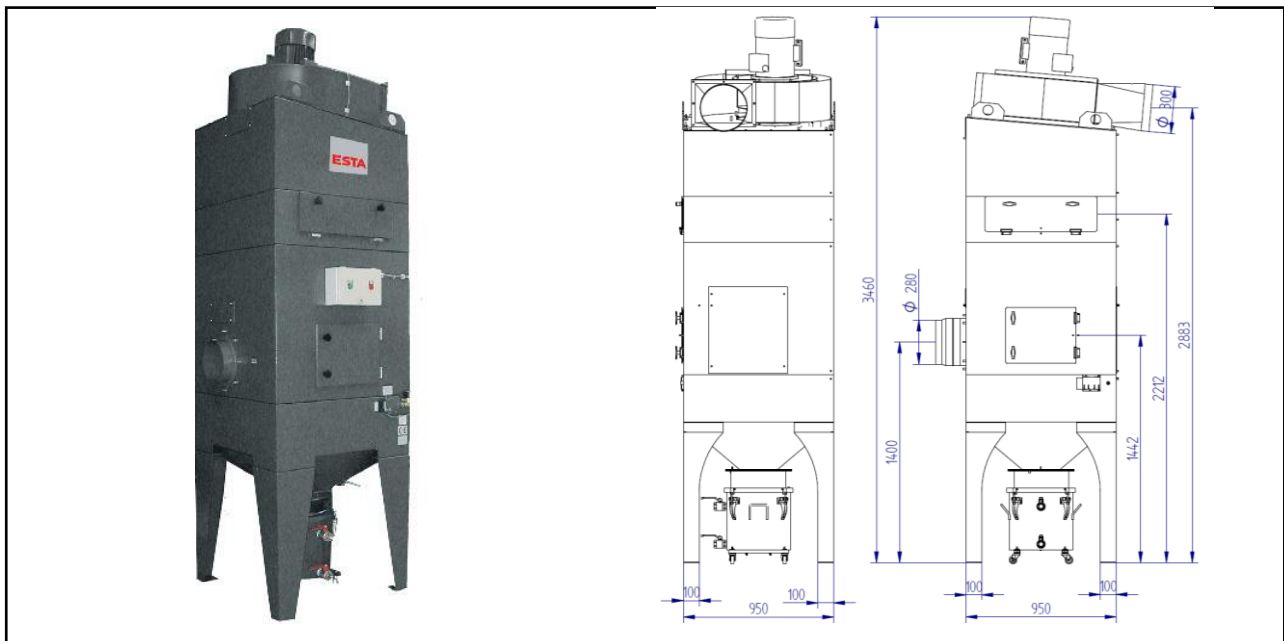

ESTA PLUS

Application range:

- Extraction of aluminium dust
- Dust extraction at individual or multiple workstations of adhesive and moistly dusts, especially metallic dusts that are sparks generating
- As central exhaust station with intercepting pipe and several extraction points

Your benefits at a glance

- High suction power for adhesive and moistly dusts
- Ideal solution for sparks generating applications
- High filtration efficiency (ESTA efficiency guarantee)

Characteristics:

- Especially recommended for grinding applications that are generating sparks Integrated c

Custom design/optional:

- with special painting

State of the art: 45183-51-00 Subject to change without notice! For remaining questions please do not hesitate to contact us..