

NA-K 3600 VA

(45.360)

Voltage	(V)	400	Water capacity	390
Motor	(kW)	5,5	Water connection	G ¾"
Current (400V/50Hz)	(A)	10,9	Intake diameter	(mm) 224/280
Fuse	(A)	32	Weight (without water)	(Kg) 510
max. neg. pressure	(Pa)	3.500	Sludge tank	(Liter) 50
max. airflow	(m³/h)	3.125	Dimensions (L x B x H)	(mm) 950 x 950 x 3.510

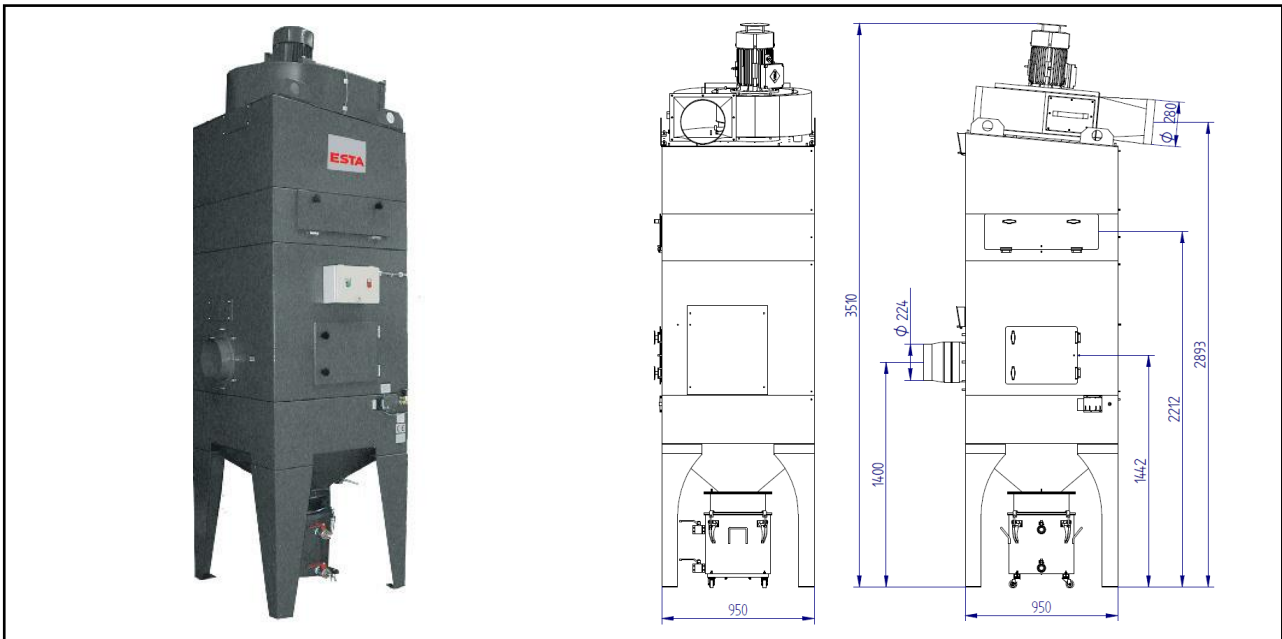

ESTA PLUS

Application range:

- Extraction of aluminium dust
- Dust extraction at individual or multiple workstations of adhesive and moistly dusts, especially metallic dusts that are sparks generating
- As central exhaust station with intercepting pipe and several extraction points

Your benefits at a glance

- High suction power for adhesive and moistly dusts
- Ideal solution for sparks generating applications

Characteristics:

- Completely made of stainless steel
- Integrated control cabinet

Custom design/optional:

- with special painting

State of the art: 45360-51-00 Subject to change without notice! For remaining questions please do not hesitate to contact us..

ESTA Apparatebau GmbH & Co. KG
Gotenstraße 2 – 6
89250 Senden

Telefon 07307 804-0
Telefax 07307 804-500
E-Mail info@esta.com

www.esta.com