

## SRF K-10

(55.203)

Voltage	(V)	230	max. neg. pressure	(Pa)	2.800
Motor	(kW)	1,3	max. air flow	(m <sup>3</sup> /h)	950
Filter surface	(m <sup>2</sup> )	10	Weight	(kg)	69
Rated frequency	(Hz)	50	Intake diameter	(mm)	2 x 50
Mode of operation		S3	Dimensions (L x B x H)	(mm)	490 x 400 x 560
Sound level	dB (A)	72			

\*at 4 bar with valve opening 0,12 sec

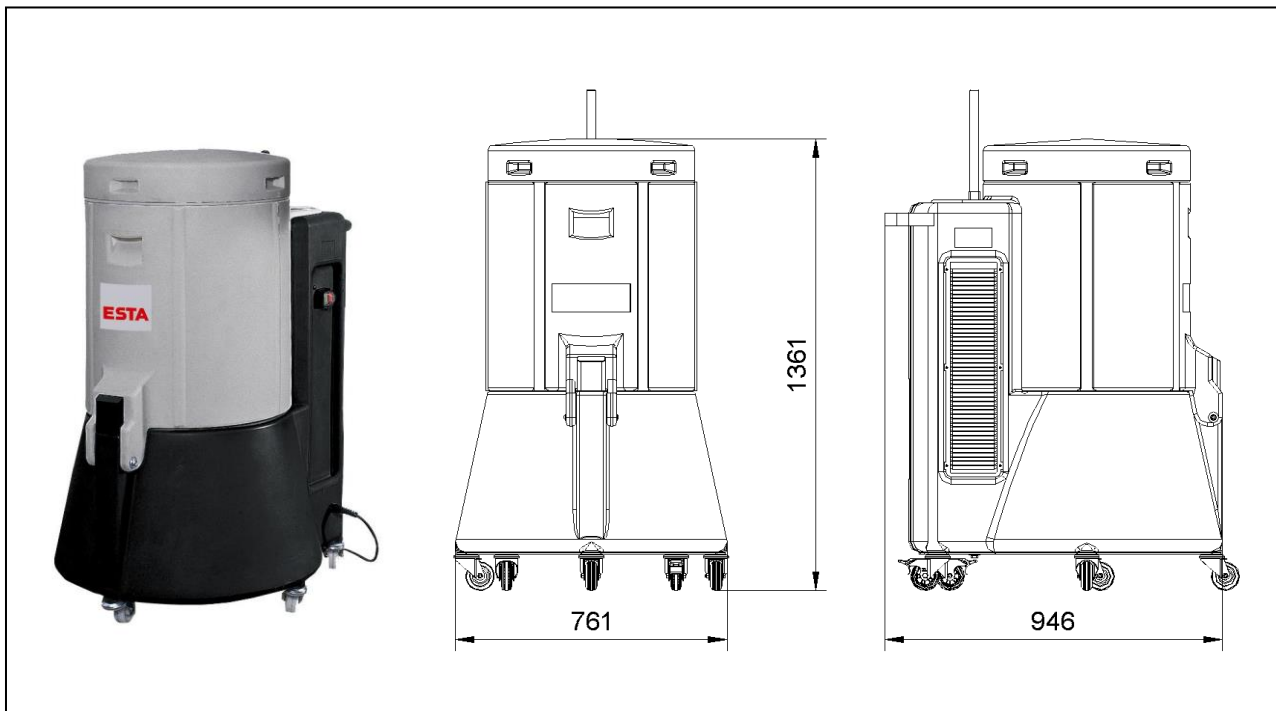

## ESTA PLUS

### Application Range:

- Intermittent and continuous duty operation
- Extraction of metallic dusts
- Suitably modified for fume extraction

### Your benefits at a glance:

- Powerful capturing of the welding fumes
- Mobile for versatile use and suitable for continuous duty applications
- Compact and user friendly design
- Low operating costs through the use of cleanable
- long life cartridge filters (dust classification „M“)
- Convenient disposal of the dust

### Characteristic:

- Filter cleaning with compressed air gun (manually)
- Special equipment with automatic cleaning,
- manual cleaning
- IFA Test Certificate W3

### Modifications:

- Special voltage
- automatic attempt via optical sensor
- attempt via start and stop contactor at the extraction cap or at the extraction arm
- AC motor
- active carbon filter
- exhaust air connection
- automatic attempt via clamp forceps

State of the art: 55203-51-01 Subject to change without notice! For remaining questions, please do not hesitate to contact us.

ESTA Apparatebau GmbH & Co. KG  
Gotenstraße 2 – 6  
89250 Senden / GERMANY

Phone +49 7307 804-0  
Fax +49 7307 804-500  
E-Mail info@esta.com

[www.esta.com](http://www.esta.com)