

OILMAC 400

(56.200)

Motor	(kW)	0,24	max. airflow	(m ³ /h)	420
Voltage	(V)	230	Sound level	(dBA)	66
Rated frequency	(Hz)	50	Weight	(kg)	ca. 50
Intake	(mm)	150	Dimensions	(mm)	640x650x510

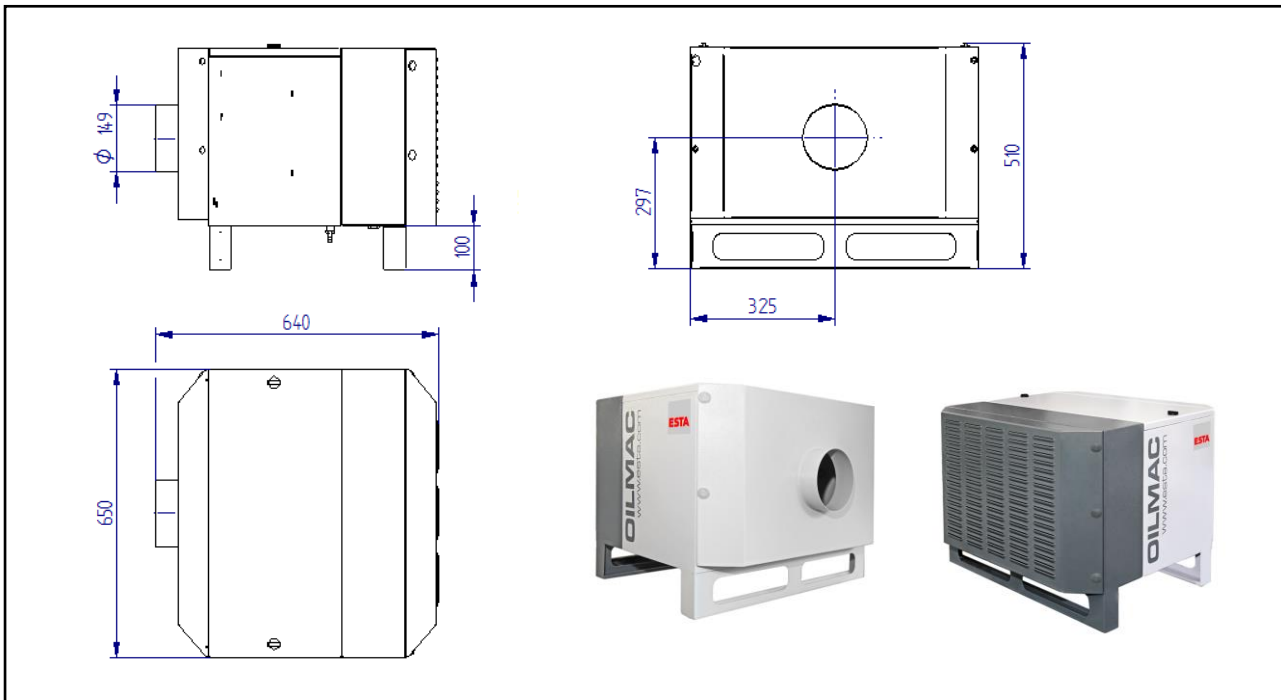

ESTA PLUS

Application range:

- Extraction of oil and emulsion mist
- Minimal lubrication mist and smoke

Characteristics:

- Mechanical filtration
- With postfilter H13 for recirculation mode

Your benefits at a glance:

- Compact unit for the extraction of oil and emulsion mist
- Easy installation on top of the processing machine
- Three power ratings available
- Multi-filter system

Modification:

- With motor protection switch
- With potential free contact
- With special voltages
- With exhaust air connection
- With special painting
- Mobile on wheels
- With stand for adjacent installation

State of the art: 56200-51-00. Subject to change without notice! For remaining questions, please do not hesitate to contact us.

ESTA Apparatebau GmbH & Co. KG
Gotenstraße 2 – 6
89250 Senden

Telefon 07307 804-0
Telefax 07307 804-500
E-Mail info@esta.com

www.esta.com