

OILMAC 800

(56.201)

Motor	(kW)	0,55
Voltage	(V)	400
Rated frequency	(Hz)	50
Intake	(mm)	200

max. airflow	(m ³ /h)	540
Sound level	(dBA)	69
Weight	(kg)	ca. 80
Dimensions	(mm)	1.140x685x475

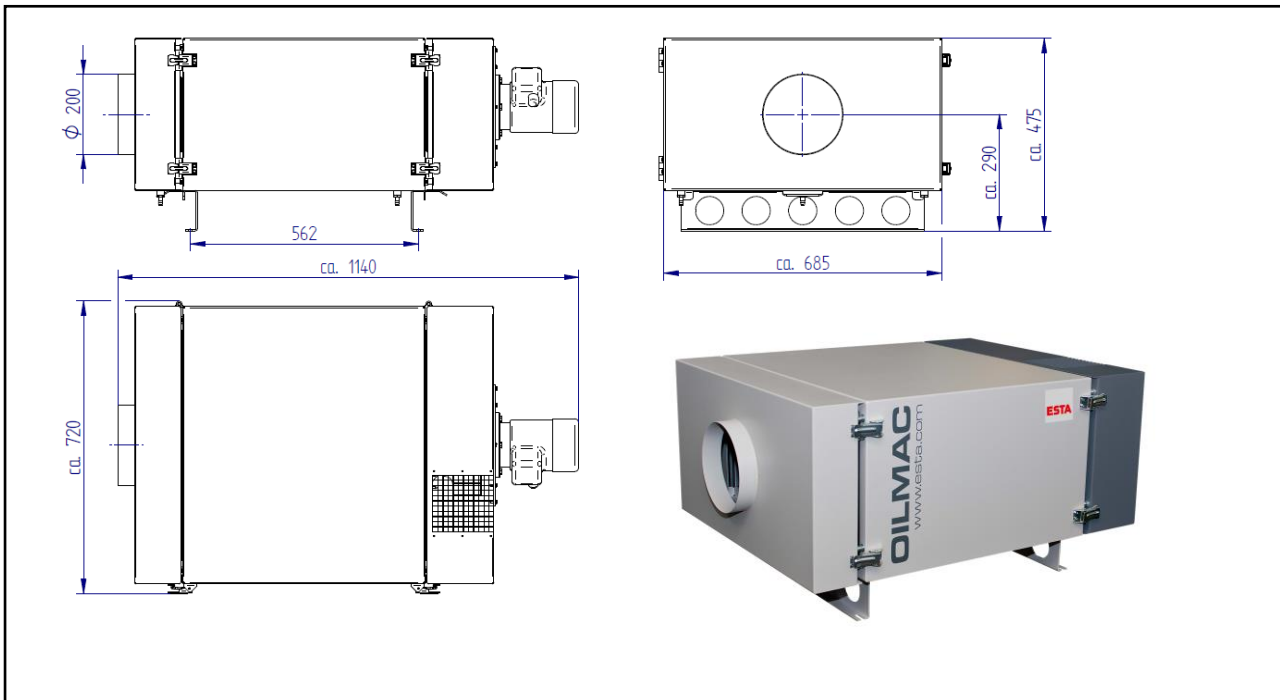

ESTA PLUS

Application range:

- Extraction of oil and emulsion mist
- Minimal lubrication mist and smoke

Your benefits at a glance:

- Compact unit for the extraction of oil and emulsion mist
- Easy installation on top of the processing machine
- Three power ratings available
- Multi-filter system

Characteristics:

- Mechanical filtration
- With postfilter H13 for recirculation mode

Modification:

- With motor protection switch
- With potential free contact
- With special voltages
- With exhaust air connection
- With special painting
- Mobile on wheels
- With stand for adjacent installation

State of the art: 56201-51-00 Subject to change without notice! For remaining questions, please do not hesitate to contact us.

ESTA Apparatebau GmbH & Co. KG
Gotenstraße 2 – 6
89250 Senden

Telefon 07307 804-0
Telefax 07307 804-500
E-Mail info@esta.com

www.esta.com