

DUSTMAC S-25

(662.025)

Voltage	(V)	400	Filter surface	(m ²)	25
Motor	(kW)	5.5	No. of filter elements	(pc)	48
Ampere (400V/50Hz)	(A)	10.6	Filter material	dust classification M	
Rated Frequency	(Hz)	50	Weight	(kg)	850
Fuse	(A)	C 16	Intake	(mm)	315
Max. neg. pressure	(Pa)	3,500	Clean air discharge	(mm)	355
Max. airflow	(m ³ /h)	5,500	Dimensions (l x w x h)	(mm)	1,820 x 1,310 x 4,030
No. of magnet valves	(pc)	8	Dust collection bin	(litre)	50
Sound level*	(dB)	78	Compressed air	(l/min)	(at 6 bar) 162

*Measured according to the enveloping body method DIN EN ISO 3744 with an attached suction side piping and pressure side attached silencer. Measurement uncertainty noise approx. 4 dBA

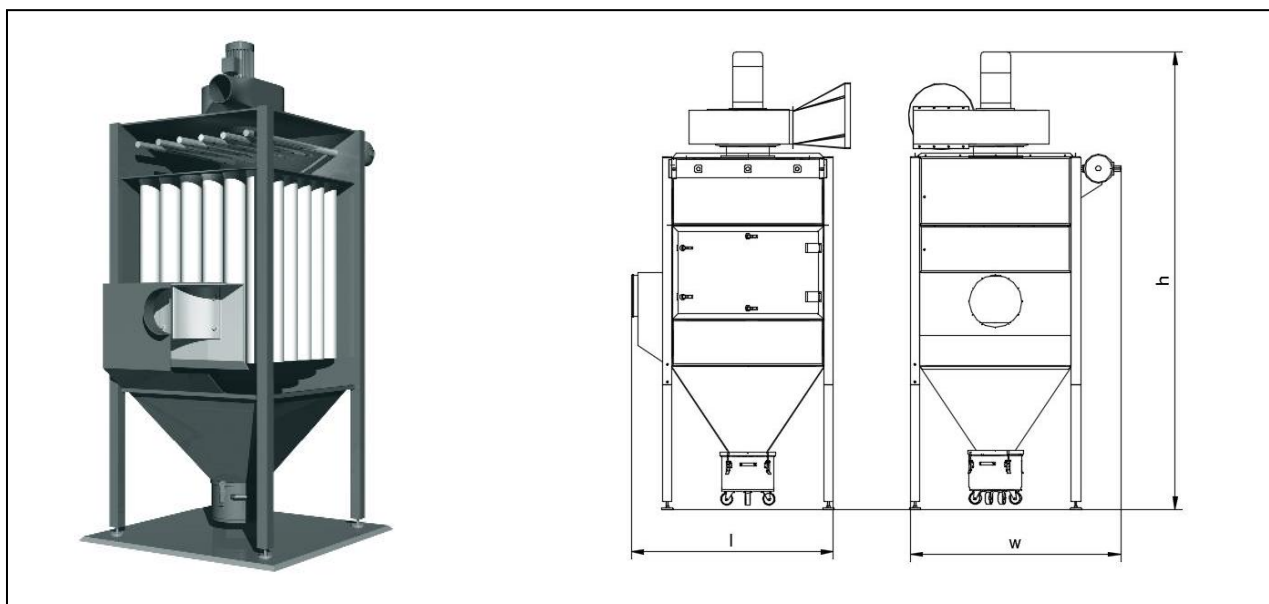

ESTA PLUS

Application range:

Central systems for multiple extraction locations of fine, long fibers and sticky dust

Your benefits at a glance

Modular for future expansion
Suitable for fine, long fibers and sticky dust
Customized design by ESTA personnel

Characteristics:

Pulse-jet filter cleaning system
Cleanable, tubular bag filters of dust classification M

Special equipment:

- with special painting
- continuously electrically conductive
- extended feet
- further special versions available on request

State of the art: 662025-51-04 Subject to change without notice! For remaining questions, please do not hesitate to contact us.