

## EUROSOG-W/N

(80.198)

Voltage	(V)	230	Filter surface pre-filter, „M“	(m <sup>2</sup> )	2
Motor	(kW)	3 x 1,0	Filter surface main filter	(m <sup>2</sup> )	2
Current	(A)	13	Filter cleaning		manuell
Rated frequency	(Hz)	50	Weight	(kg)	74
Fuse	(A)	16	Intake	(mm)	50
Max. neg. pressure	(Pa)	18.600	Dust collection bin	(Liter)	80
Max. airflow	(m <sup>3</sup> /h)	360	Dimension (L x W x H)	(mm)	932 x 660 x 1.140
Sound level	(dBA)	74			

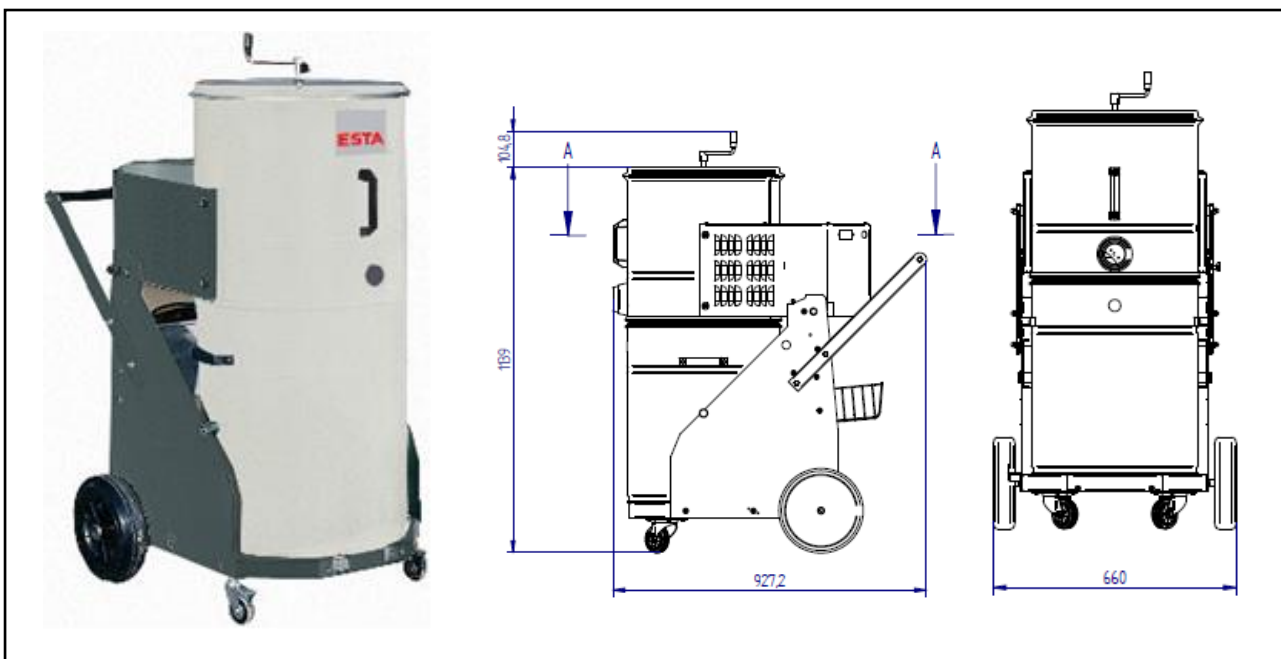

## ESTA PLUS

### Application range:

- Removal of coarse and fine dust during cleaning works

### Your benefits at a glance:

- Powerful industrial vacuum cleaner for dry, pourable types of dust
- Tight and easy-to-handle design
- Easy disposal of the dust collection bag
- Great range of products of accessories for the vacuum cleaner

### Characteristics:

- Filter cleaning: manual brush cleaning
- Cleanable long life cartridge filters (dust classification M)
- Patented tiltable filter housing
- Alternating current device
- Test Certificate: dust classification "M"

### Modification:

- With different filter cartridges
- Special voltage, Special painting, Mobile dust collection bin, Installation of a pre-separator possible

State of the art: 80198-51-01 Subject to change without notice! For remaining questions please do not hesitate to contact us..

ESTA Apparatebau GmbH & Co. KG  
Gotenstraße 2 – 6  
89250 Senden

Telefon 07307 804-0  
Telefax 07307 804-500  
E-Mail info@esta.com

[www.esta.com](http://www.esta.com)