

DUROSOG-W/H

(80.24H)

Voltage	(V)	230	Filter surface pre-filter „M“	(m ²)	3
Motor	(kW)	3 x 1,0	No. of filter elements	(pc)	1
Current	(A)	13	Filter material	dust classification "H"	
Rated frequency	(Hz)	50	Weight	(kg)	41
Fuse	(A)	16	Intake	(mm)	50
Max. neg. pressure	(Pa)	22.000	Dust collection bin	(Liter)	70
Max. airflow	(m ³ /h)	350	Dimension (L x W x H)	(mm)	660 x 630 x 950

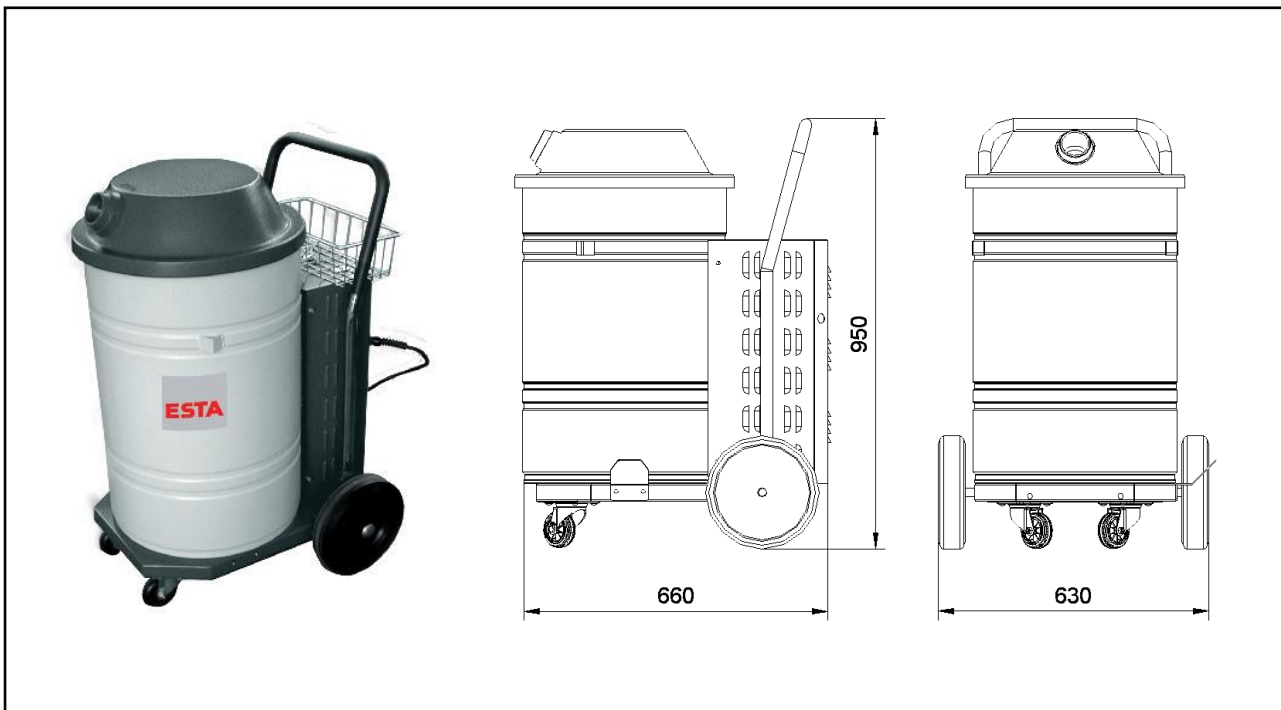

ESTA PLUS

Application range:

- For sticky substances and dust that tends to clump
- Removal of dusts that are hazardous to health and cancer-causing

Your benefits at a glance:

- With the use of special filtration technology this model is suitable for dry dust, sticky dust and dust that tends to clump
- Tight and easy-to-handle design

Characteristics:

- Equipped with pre-separator
- paper filter bag
- cloth filter
- bag and long life cartridge filter (dust classification H)
- 3 x suction turbine with 230 Volt
- Test Certificate: dust classification "H"

Modification:

- Special voltage
- Special painting
- Installation of a pre-separator possible

State of the art: 8024H-51-00 Subject to change without notice! For remaining questions please do not hesitate to contact us..