

## DUROSOG-I-D/H

(81.20H)

Voltage	(V)	400	Filter surface pre-filter, „M“	(m <sup>2</sup> )	3
Motor	(kW)	2,2	No. of filter elements	(pc)	1
Ampere	(A)	4,5	Filter material	dust classification “H”	
Rated frequency	(Hz)	50	Weight	(kg)	80
Fuse	(A)	16	Intake	(mm)	50
Max. neg. pressure	(Pa)	22.000	Dust collection bin	(Liter)	70
Max. airflow	(m <sup>3</sup> /h)	275	Dimension (L x W x H)	(mm)	850 x 630 x 950

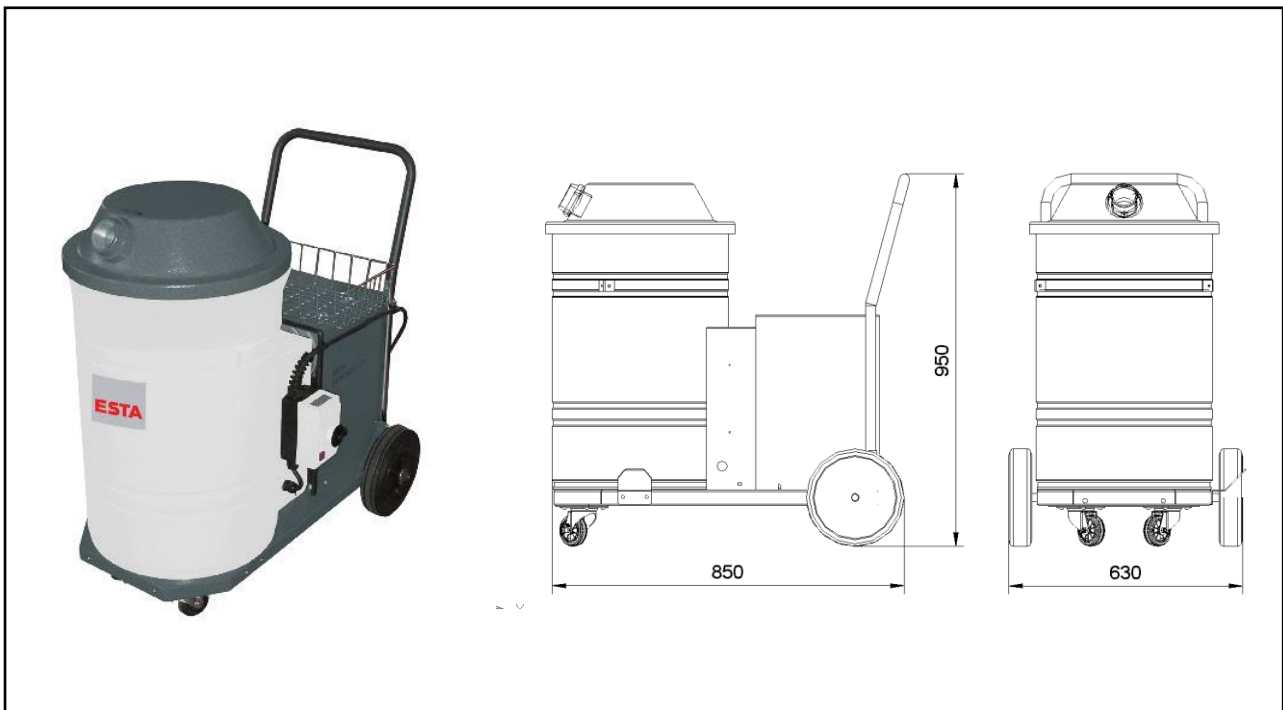

## ESTA PLUS

### Application range:

- For sticky substances and dust that tends to clump
- Removal of dusts that are hazardous to health

### Your benefits at a glance:

- With the use of special filtration technology this model is suitable for dry dust, sticky dust and dust that tends to clump
- Tight and easy-to-handle design
- Convenient dust disposal in a paper filter bag

### Characteristics:

- Equipped with pre-separator
- paper filter bag
- cloth filter
- bag and long life cartridge filter (dust classification H)
- Test Certificate: dust classification "H"

### Modification:

- Special voltage
- Special painting
- Installation of a pre-separator possible

State of the art: 8120H-51-00 Subject to change without notice! For remaining questions please do not hesitate to contact us..