

WHISPERSOG 3.0 FM

(83.102)

Voltage	(V)	400	Filter surface pre-filter, „M“	(m ²)	2
Motor	(kW)	2,2	No. of filter elements	(pc)	1
Ampere	(A)	4,5	Filter material	dust classification “M”	
Rated frequency	(Hz)	50	Filter cleaning	manual	
Fuse	(A)	16	Weight	(kg)	120
Max. neg. pressure	(Pa)	31.500	Intake	(mm)	50
Max. airflow	(m ³ /h)	216	Dust collection bin	(Liter)	80
			Dimension (L x W x H)	(mm)	1.300 x 640 x 1.250

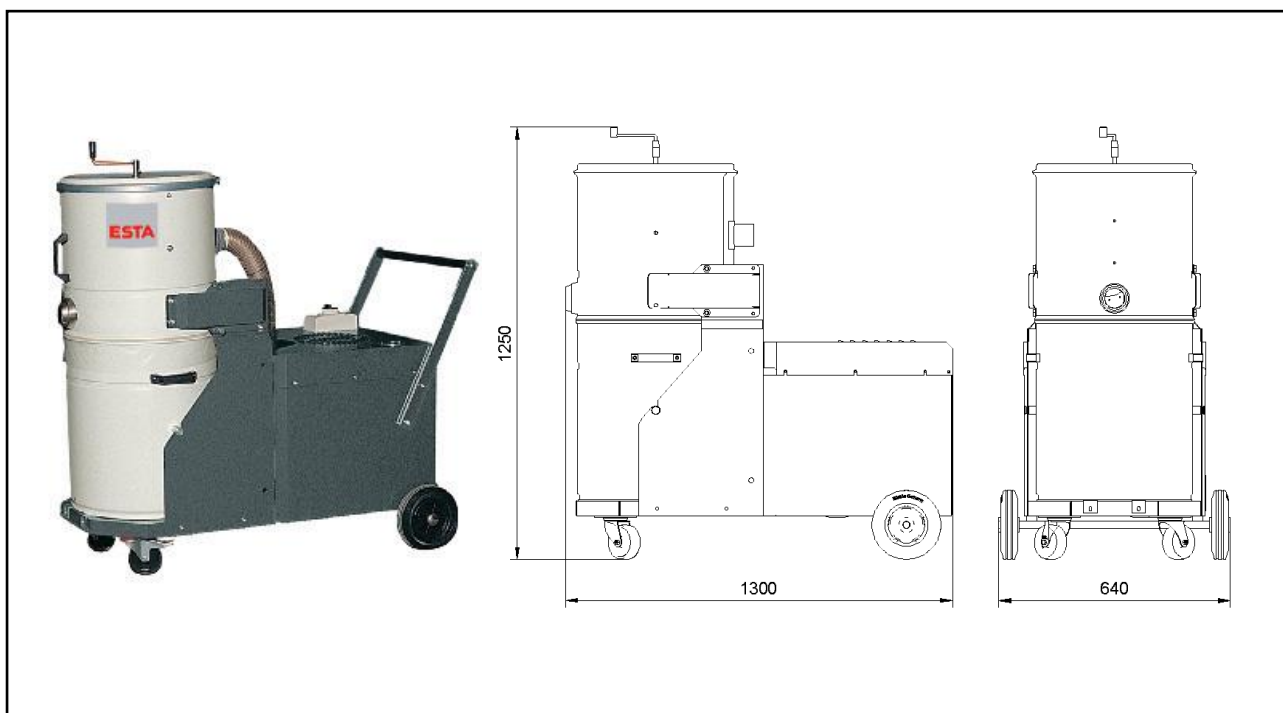

ESTA PLUS

Application range:

- Removal of coarse, fine and pourable dust during cleaning works

Characteristics:

- Filter cleaning: manual brush cleaning mechanism

Your benefits at a glance:

- Very quiet and powerful vacuum cleaner for dry dust
- Designed for continuous operation
- Cleanable long life cartridge filters with dust classification M
- Easy disposal of the dust collection bag by a patented tiltable filter housing

Modification:

- Special voltage
- Special painting
- Installation of a pre-separator possible
- With different filter cartridges

State of the art: 83102-51-00 Subject to change without notice! For remaining questions please do not hesitate to contact us..

ESTA Apparatebau GmbH & Co. KG
Gotenstraße 2 – 6
89250 Senden

Telefon 07307 804-0
Telefax 07307 804-500
E-Mail info@esta.com

www.esta.com